

THIS DOCUMENT CONTAINS (11) PAGES.
ENGINEER DIGITAL OR ORIGINAL HAND SEAL REQUIRED FOR USE.
COPIES ARE NOT VALID FOR PERMIT.

(Subject to Renew July 1, 2024 or next code cycle)

EVALUATION SUBJECT: **PACKAGED UNITS**

TER-22-55956

REPORT HOLDER:

NORTEK GLOBAL HVAC
8000 PHOENIX PARKWAY
O'FALLON, MO 63368 USA
(800) 422-4328 | NORTEK.COM



SCOPE OF EVALUATION (compliance with the following codes):

THIS IS A STRUCTURAL (WIND) PERFORMANCE EVALUATION ONLY. NO ELECTRICAL OR TEMPERATURE PERFORMANCE RATINGS OR CERTIFICATIONS ARE OFFERED OR IMPLIED HEREIN. UNDER NO CIRCUMSTANCE DOES THIS PERFORMANCE EVALUATION GUARANTEE, IMPLY, OR STATE PERFORMANCE OF THE UNIT IS MAINTAINED DURING OR AFTER A DESIGN EVENT.

This Product Evaluation Report is being issued in accordance with the requirements of the **Florida Building Code Seventh Edition (2020)** per ASCE 7, FBC Building Ch. 16, FBC Building Sections 104.11 & 1522.2, FBC Existing Building Sections 707.1 & 707.2, FBC Mechanical 301.15, FBC Residential M1202.1 & M1301.1, FS 471.025, and Broward County Administrative Provisions 107.3.4. This report is also in accordance with the **International Building & Residential Codes (2012, 2015, & 2018)**. The product noted on this report has been tested and/or evaluated as summarized herein.

IN ACCORDANCE WITH THESE CODES EACH OF THESE REPORTS MUST BEAR THE ORIGINAL SIGNATURE & RAISED SEAL OR DIGITAL SEAL OF THE EVALUATING ENGINEER.

SUBSTANTIATING DATA:

• Product Evaluation Documents

Substantiating documentation has been submitted to provide this TER and is summarized in the sections below.

• Structural Engineering Calculations

Structural engineering calculations have been prepared which evaluate the product based on comparative and/or rational analysis to qualify the following design criteria:

- Max. allowable lateral & uplift wind pressures certified herein
- Max. allowable sliding forces, uplift forces, & overturning moments (see Unit Reactions from Wind Guide on last page)
- Tie-down configuration and anchor capacity for concrete, aluminum, and steel host substrates (host by others).
- Unit panel wind pressure connection integrity

Calculation summary is included in this TER and appears herein. NOTE: No 33% increase in allowable stress has been used in the design of this product.

LIMITATIONS & CONDITIONS OF USE:

Use of the product(s) listed herein shall be in strict accordance with this TER as noted herein and manufacturer-provided model specifications. Installation shall conform to the minimum standards stated in the referenced building code(s) in addition to the specifications and limitations stated herein. See herein for complete limitations & conditions of use.

OPTIONS:

This evaluation is valid for the NORTEK models described herein. The critical unit designs have been determined and used in this evaluation. Any structural changes outside of the design as described herein would void this certification.

UNIT CASING MATERIALS:

20ga galvanized metal sheet ASTM A653 steel for removable top panel. 18ga galvanized metal sheet ASTM A653 steel for base pan. Cabinets A, B, & C with 22ga galvanized metal sheet ASTM A653 for side protector panels A, B, D, 20ga galvanized metal sheet ASTM A653 for side protector panels C, G, 18ga galvanized metal sheet ASTM A653 for side protector panels E, F. Cabinet D, E, 22ga galvanized metal sheet ASTM A653 for side protector panels A, B, D and 20ga galvanized metal sheet ASTM A653 for side protector panels C; secured with SAE 1022 #10 sheet metal screws into top and base pan. Contact report holder for further unit construction information.

NOTE: THE GRAPHICAL DEPICTIONS IN THIS REPORT ARE FOR ILLUSTRATIVE PURPOSES ONLY AND MAY DIFFER IN APPEARANCE.

STRUCTURAL PERFORMANCE:

Models referenced herein are subject to the following design limitations:

Maximum Rated Wind Pressures*:
± 118 psf Lateral, 93 psf Uplift

- Required design wind pressures shall be determined according to the guide provided in the Appendix (see last page of this report) or on a site-specific basis in accordance with ASCE 7 and applicable sections of the building code(s) being referenced in accordance with ASD methodology.

- Required design pressures shall be less than or equal to the maximum pressures listed herein.

- *Maximum Rated Wind Pressures indicate the maximum pressures that all units listed herein are approved for. Valid for at-grade and rooftop applications. See limitations herein.

- Valid for use inside and outside the High-Velocity Hurricane Zone (HVHZ).

- Site-specific wind analysis may produce alternate limitations provided maximum rated wind pressures stated herein are not exceeded.

VISIT [ECALC.IO/55956](https://ecalcalc.io/55956)

FOR ENGINEER CERTIFIED ORIGINALS & MORE
INFORMATION ABOUT THIS DOCUMENT OR SCAN
THE QR CODE TO THE RIGHT >

VISIT [ENGINEERINGEXPRESS.COM/STORE](https://engineeringexpress.com/store) FOR
ADDITIONAL PLANS, REPORTS & RESOURCES



ORIGINAL SIGNATURE AND RAISED SEAL
OR DIGITAL SEAL REQUIRED TO BE VALID PER CODE:

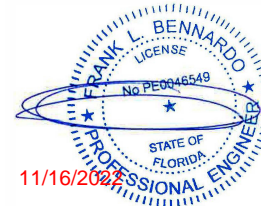

November 2, 2022

VALID ONLY FOR ZIP CODE: 00000

VALID ONLY FOR: MANUFACTURER RECORDS ONLY

NOT VALID FOR PERMIT USE

PE0046549 CA-9885

DIGITAL SEAL NOTICE: IF THIS DOCUMENT IS DIGITALLY SIGNED, THIS SHEET IS PART OF A DIGITALLY SIGNED FILE. IT SHALL REMAIN IN DIGITAL FORMAT, SHALL BE VERIFIED BY ELECTRONIC MEANS, & PRINTED COPIES OF THIS DOCUMENT ARE NOT CONSIDERED SIGNED AND SEALED. VISIT [ECALC.IO/DS](https://ecalcalc.io/ds) FOR MORE INFORMATION.

PRINTED DOCUMENT NOTICE: IF THIS DOCUMENT IS PRINTED & DOES NOT CONTAIN AN ENGINEER'S ORIGINAL SIGNATURE & SEAL, THIS DOCUMENT IS VOID & NOT VALID FOR USE. PHOTOCOPIES ARE NOT PERMITTED FOR USE.

Copyright © Engineering Express® All Rights Reserved

MODEL INFORMATION (Continued on Following Pages)

Model Number	Length (in)	Width (in)	Height (in)	Depth (in)	Cabinet
*P94RD-024K	-	35	22.2	49	D
*P94RD-030K	-	35	22.2	49	D
*P94RD-036K	-	35	22.2	49	D
*P94RD-042K	-	35	30.2	49	D
*P94RD-048K	-	35	30.2	49	D
*P94RD-060K	-	35	38.2	63	E
*Q104SD-X24K	47.5	55.8	39	-	A
*Q104SD-X30K	47.5	55.8	39	-	A
*Q104SD-X36K	47.5	55.8	39	-	A
*Q104SD-X42K	47.5	55.8	43	-	B
*Q104SD-X48K	47.5	55.8	43	-	B
*Q104SD-X60K	47.5	55.8	43	-	B
*Q94RD-024K	-	35	30.2	49	D
*Q94RD-030K	-	35	30.2	49	D
*Q94RD-036K	-	35	30.2	49	D
*Q94RD-042K	-	35	30.2	49	D
*Q94RD-048K	-	35	38.2	63	E
*Q94RD-060K	-	35	38.2	63	E
*R104GD-024K045C	47.5	55.8	35	-	A
*R104GD-024K072C	47.5	55.8	35	-	A
*R104GD-030K045C	47.5	55.8	35	-	A
*R104GD-030K072C	47.5	55.8	35	-	A
*R104GD-036K072C	47.5	55.8	35	-	A
*R104GD-036K096C	47.5	55.8	35	-	A
*R104GD-042K072C	47.5	55.8	39	-	A
*R104GD-042K096C	47.5	55.8	39	-	A
*R104GD-048K096C	47.5	55.8	43	-	B
*R104GD-048K120C	47.5	55.8	43	-	B
*R104GD-X60K096C	47.5	55.8	43	-	B
*R104GD-X60K120C	47.5	55.8	43	-	B
R104HD-X24K060C	47.5	55.8	35	-	A
R104HD-X30K060C	47.5	55.8	35	-	A
R104HD-X36K080C	47.5	55.8	35	-	A
R104HD-X42K080C	47.5	55.8	39	-	A
R104HD-X48K096C	47.5	55.8	43	-	B
R104HD-X60K096C	47.5	55.8	47	-	B

SEE MODEL NOTES SECTION HEREIN

MODEL INFORMATION CONTINUED (Continued from Previous/Following Pages)

Model Number	Length (in)	Width (in)	Height (in)	Cabinet
P7RE-018K	49	35	22.2	D
P7RE-024K	49	35	22.2	D
P7RE-030K	49	35	22.2	D
P7RE-036K	49	35	22.2	D
P7RE-042K	49	35	30.2	D
P7RE-048K	49	35	30.2	D
P7RE-X60KA	49	35	34.2	D
P7RF-X24K	49	35	30.2	D
P7RF-X36K	49	35	30.2	D
P7RF-X48K	49	35	38.2	E
P7RF-X60K	63	35	38.2	E
PPA3RFX24K	49	35	30.2	D
PPA3RFX36K	49	35	30.2	D
PPA3RFX48K	49	35	38.2	E
PPA3RFX60K	63	35	38.2	E
PPH3RFX24K	49	35	30.2	D
PPH3RFX36KA	49	35	38.2	E
PPH3RFX48K	63	35	38.2	E
PPH3RFX60K	63	35	38.2	E
Q7RE-024K	49	35	30.2	D
Q7RE-030K	49	35	30.2	D
Q7RE-036K	49	35	30.2	D
Q7RE-042K	49	35	30.2	D
Q7RE-048K	63	35	38.2	E
Q7RE-060K	63	35	38.2	E
Q7RF-X24K	49	35	30.2	D
Q7RF-X36KA	49	35	30.2	D
Q7RF-X48K	63	35	30.2	D
Q7RF-X60K	63	35	30.2	D
RP7RE-018K	49	35	22.2	D
RP7RE-024K	49	35	22.2	D

Model Number	Length (in)	Width (in)	Height (in)	Cabinet
RP7RE-030K	49	35	22.2	D
RP7RE-036K	49	35	22.2	D
RP7RE-042K	49	35	30.2	D
RP7RE-048K	49	35	30.2	D
RP7RE-X60KA	49	35	34.2	D
RP7RF-X24K	49	35	30.2	D
RP7RF-X36K	49	35	30.2	D
RP7RF-X48K	49	35	38.2	E
RP7RF-X60K	63	35	38.2	E
RQ7RE-024K	49	35	30.2	D
RQ7RE-030K	49	35	30.2	D
RQ7RE-036K	49	35	30.2	D
RQ7RE-042K	49	35	30.2	D
RQ7RE-048K	63	35	38.2	E
RQ7RE-060K	63	35	38.2	E
VP7RE-024K	49	35	22.2	D
VP7RE-030K	49	35	22.2	D
VP7RE-036K	49	35	22.2	D
VP7RE-042K	49	35	30.2	D
VP7RE-048K	49	35	30.2	D
VP7RE-X60KA	49	35	34.2	D
VQ7RE-024K	49	35	30.2	D
VQ7RE-030K	49	35	30.2	D
VQ7RE-036K	49	35	30.2	D
VQ7RE-042K	49	35	30.2	D
VQ7RE-048K	63	35	38.2	E
VQ7RE-060K	63	35	38.2	E

SEE MODEL NOTES SECTION HEREIN

MODEL INFORMATION CONTINUED (Continued from Previous/Following Pages)

Model Number	Length (in)	Width (in)	Height (in)	Cabinet
DF6SF-X24K080CB	47.5	55.8	39	A
DF6SF-X36K100CB	47.5	55.8	43	B
DF6SF-X48K120CB	47.5	55.8	43	B
DF6SF-X60K120CB	47.5	63.6	47	C
P8SE-X36C	47.5	55.8	39	A
P8SE-X36D	47.5	55.8	39	A
P8SE-X36K	47.5	55.8	39	A
P8SE-X48C	47.5	55.8	39	A
P8SE-X48D	47.5	55.8	39	A
P8SE-X48K	47.5	55.8	39	A
P8SE-X60C	47.5	55.8	43	B
P8SE-X60D	47.5	55.8	43	B
P8SE-X60K	47.5	55.8	43	B
PDF2SFX24K080CB	47.5	55.8	39	A
PDF2SFX36K100CB	47.5	55.8	43	B
PDF2SFX48K120CB	47.5	55.8	43	B
PDF2SFX60K120CB	47.5	63.6	47	C
PPA3SE-X36K	47.5	55.8	39	A
PPA3SE-X48K	47.5	55.8	39	A
PPA3SE-X60K	47.5	55.8	43	B
PPG2GFX24K080XA	47.5	55.8	39	A
PPG2GFX36K100XA	47.5	55.8	39	A
PPG2GFX48K120XA	47.5	55.8	47	B
PPG2GFX60K120XA	47.5	63.6	47	C
PPG3GE024K045C	47.5	55.8	35	A
PPG3GE024K072C	47.5	55.8	35	A
PPG3GE030K045C	47.5	55.8	35	A
PPH2SEX24K	47.5	55.8	39	A
PPH2SEX30K	47.5	55.8	39	A
PPH2SEX36K	47.5	55.8	39	A
PPH2SEX42K	47.5	55.8	43	B
PPH2SEX48K	47.5	55.8	43	B
PPH2SEX60K	47.5	55.8	43	B
Q6SE-X24K	47.5	55.8	39	A
Q6SE-X30K	47.5	55.8	39	A
Q6SE-X36K	47.5	55.8	39	A
Q6SE-X42K	47.5	55.8	43	B
Q6SE-X48K	47.5	55.8	43	B
Q6SE-X60K	47.5	55.8	43	B
R6GF-X24K080XB	47.5	55.8	39	A
R6GF-X36K100XB	47.5	55.8	39	A
R6GF-X48K120XB	47.5	55.8	47	B
R6GF-X60K120XB	47.5	63.6	47	C
VR8GE-024K045C	47.5	55.8	35	A
VR8GE-024K072C	47.5	55.8	35	A
VR8GE-030K045C	47.5	55.8	35	A

Model Number	Length (in)	Width (in)	Height (in)	Cabinet
VR8GE-024K045X	47.5	55.8	35	A
VR8GE-030K045X	47.5	55.8	35	A
VR8GE-030K072C	47.5	55.8	35	A
VR8GE-036K072C	47.5	55.8	35	A
VR8GE-036K072X	47.5	55.8	35	A
VR8GE-036K096C	47.5	55.8	35	A
VR8GE-042K072C	47.5	55.8	39	A
VR8GE-042K096C	47.5	55.8	39	A
VR8GE-042K096X	47.5	55.8	39	A
VR8GE-048K096C	47.5	55.8	39	A
VR8GE-048K096X	47.5	55.8	39	A
VR8GE-048K120C	47.5	55.8	39	A
VR8GE-X60K096C	47.5	55.8	43	B
VR8GE-X60K096X	47.5	55.8	43	B
VR8GE-X60K120C	47.5	55.8	43	B
PPG2GIE24K080X	47.5	55.8	39	A
PPG2GIE36K100X	47.5	55.8	39	A
PPG2GIE48K120X	47.5	55.8	47	B
PPG2GIE60K120X	47.5	63.6	47	C
PPG3GE024K045X	47.5	55.8	35	A
PPG3GE030K045X	47.5	55.8	35	A
PPG3GE030K072C	47.5	55.8	35	A
PPG3GE036K072C	47.5	55.8	35	A
PPG3GE036K072X	47.5	55.8	35	A
PPG3GE036K096C	47.5	55.8	35	A
PPG3GE042K072C	47.5	55.8	39	A
PPG3GE042K096C	47.5	55.8	39	A
PPG3GE042K096X	47.5	55.8	39	A
PPG3GE048K096C	47.5	55.8	39	A
PPG3GE048K096X	47.5	55.8	39	A
PPG3GE048K120C	47.5	55.8	39	A
PPG3GEX60K096C	47.5	55.8	43	B
PPG3GEX60K096X	47.5	55.8	43	B
PPG3GEX60K120C	47.5	55.8	43	B
PPG3HEX24K060XA	47.5	55.8	35	A
PPG3HEX30K060XA	47.5	55.8	35	A
PPG3HEX36K080XA	47.5	55.8	35	A
PPG3HEX42K080XA	47.5	55.8	39	A
PPG3HEX48K096XA	47.5	55.8	43	B
PPG3HEX60K096XA	47.5	55.8	47	B
R6GI-E24K080X	47.5	55.8	39	A
R6GI-E36K100X	47.5	55.8	39	A
R6GI-E48K120X	47.5	55.8	47	B
R6GI-E60K120X	47.5	63.6	47	C
R8GE-024K045C1	47.5	55.8	35	A
R8GE-024K072C1	47.5	55.8	35	A

SEE MODEL NOTES SECTION HEREIN

MODEL INFORMATION CONTINUED (Continued from Previous Pages)

Model Number	Length (in)	Width (in)	Height (in)	Cabinet
R8GE-030K045C1	47.5	55.8	35	A
R8GE-030K045X1	47.5	55.8	35	A
R8GE-030K072C1	47.5	55.8	35	A
R8GE-036K072C1	47.5	55.8	35	A
R8GE-036K072X1	47.5	55.8	35	A
R8GE-036K096C1	47.5	55.8	35	A
R8GE-042K072C1	47.5	55.8	39	A
R8GE-042K096C1	47.5	55.8	39	A
R8GE-042K096X1	47.5	55.8	39	A
R8GE-048K096C1	47.5	55.8	39	A
R8GE-048K096X1	47.5	55.8	39	A
R8GE-048K120C1	47.5	55.8	39	A
R8GE-X24K045X1	47.5	55.8	35	A
R8GE-X60K096C1	47.5	55.8	43	B

Model Number	Length (in)	Width (in)	Height (in)	Cabinet
R8GE-X60K096X1	47.5	55.8	43	B
R8GE-X60K120C1	47.5	55.8	43	B
R8HE-X24K060XA	47.5	55.8	35	A
R8HE-X30K060XA	47.5	55.8	35	A
R8HE-X36C080X	47.5	55.8	35	A
R8HE-X36D080X	47.5	55.8	35	A
R8HE-X36K080XA	47.5	55.8	35	A
R8HE-X42K080XA	47.5	55.8	39	A
R8HE-X48C096X	47.5	55.8	43	B
R8HE-X48D096X	47.5	55.8	43	B
R8HE-X48K096XA	47.5	55.8	43	B
R8HE-X60C096X	47.5	55.8	47	B
R8HE-X60D096X	47.5	55.8	47	B
R8HE-X60K096XA	47.5	55.8	47	B

MODEL INFORMATION NOTES

Unit dimensions listed above are unit net dimensions (as opposed to packing/shipping dimensions). Unit net weights shall be between 200 lb and 690 lb, typ. Model information listed herein is based on information provided by the client. See detail below for definitions of cabinet types (related to the panel integrity evaluation summarized herein). Please contact Report Holder for more information.

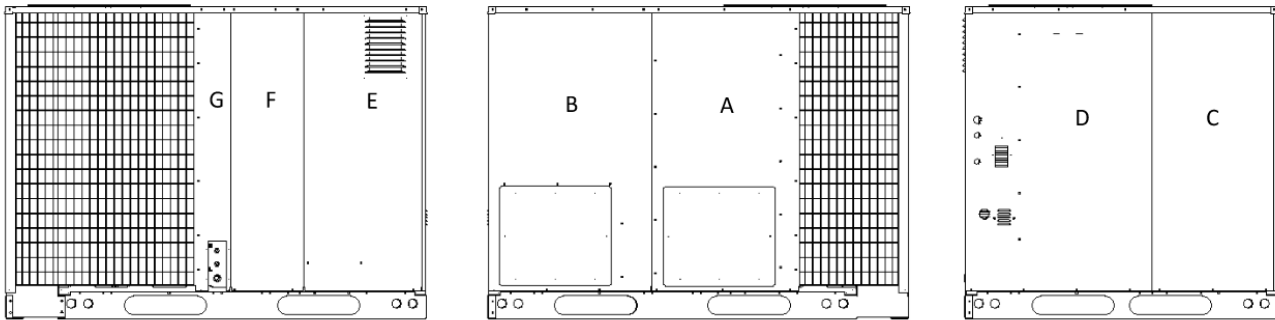

Cabinets A, B & C

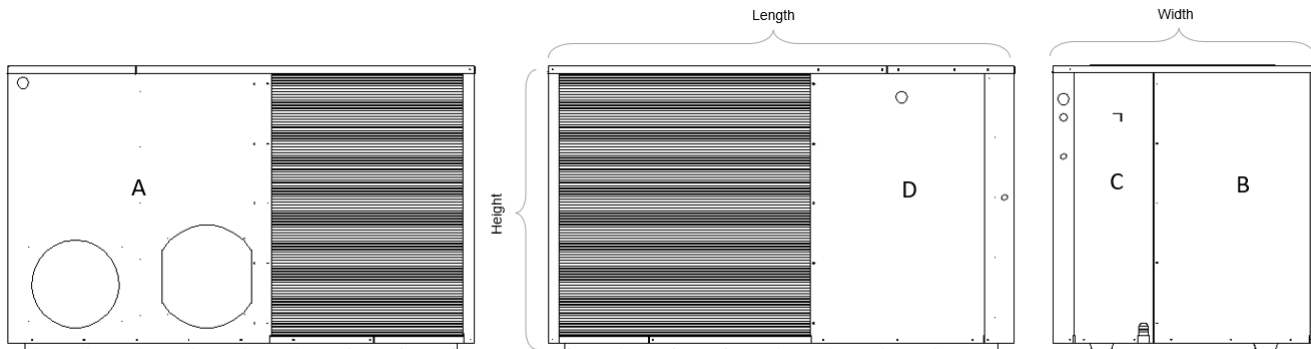

Cabinets D & E

PRODUCT INSTALLATION DETAILS (Continued on Following Page)

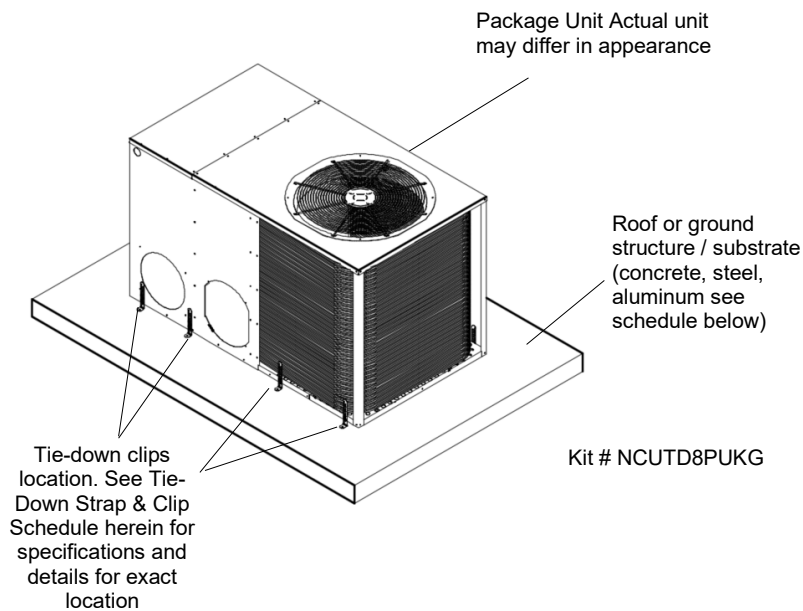

TIE-DOWN (GROUND APPLICATION)

Miami Tech CUTD 1" wide and 8" long min ASTM A653 galvanized steel 0.07" thick for all cabinets tied down at ground; fasten clip to host structure using anchor from Anchor Schedule to Host Structure Table, (2) #10-16 x 1/2" Gr2 min self-drilling screw to fasten clip to unit for cabinet D & E, (4) #10-16 x 1/2" Gr2 min self-drilling screw to fasten clip to unit for cabinet A, B & C. MIAMI-TECH KIT# NCUTD8PUKG

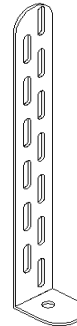

TIE-DOWN (ROOF APPLICATION)

Miami Tech CUTD 1" wide and 8" long min ASTM A653 galvanized steel 0.07" thick for cabinets D & E tied down to aluminum stand; fasten clip to host structure using anchor from Anchor Schedule to Host Structure Table, (2) #10-16 x 1/2" Gr2 min self-drilling screw to fasten clip to unit. See detail page MIAMI-TECH KIT# NCUTD8PUKR

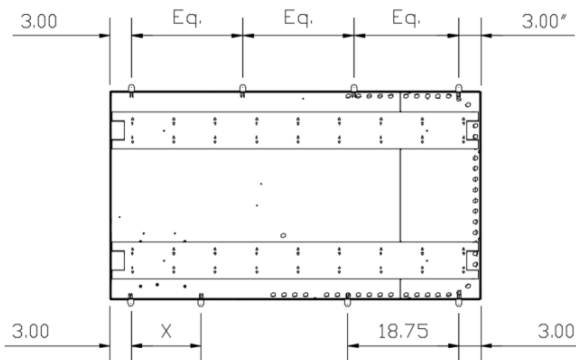

Cabinets D & E tie-down clips layout
 X = fit tie-down clip in between both duct openings and avoid label

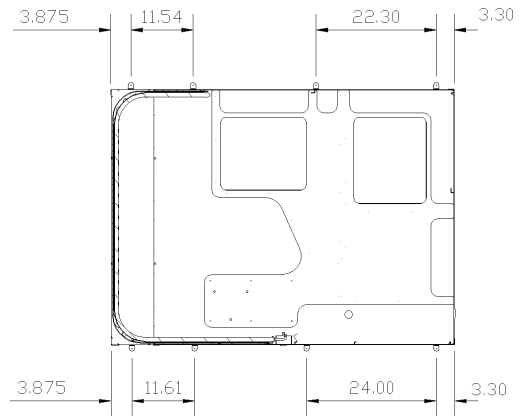

Cabinets A, B & C tie-down clips layout

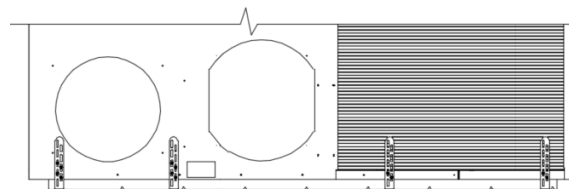

Cabinets D & E tie-down clips elevation

PRODUCT INSTALLATION DETAILS (Continued from Previous Page)

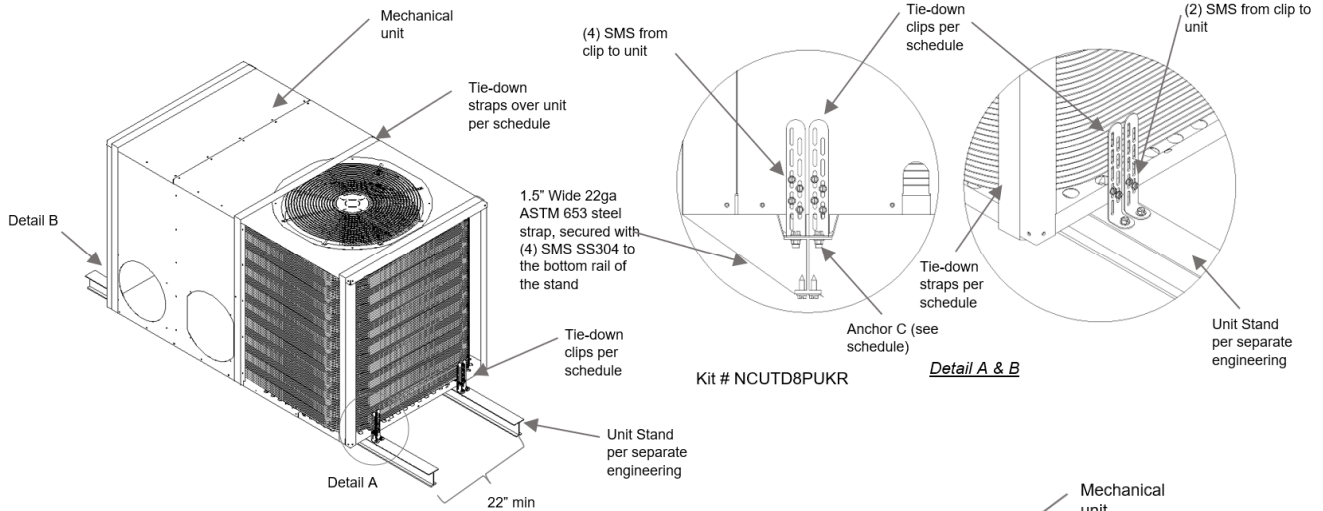

Cabinets D & E tie-down clips & strap isometric

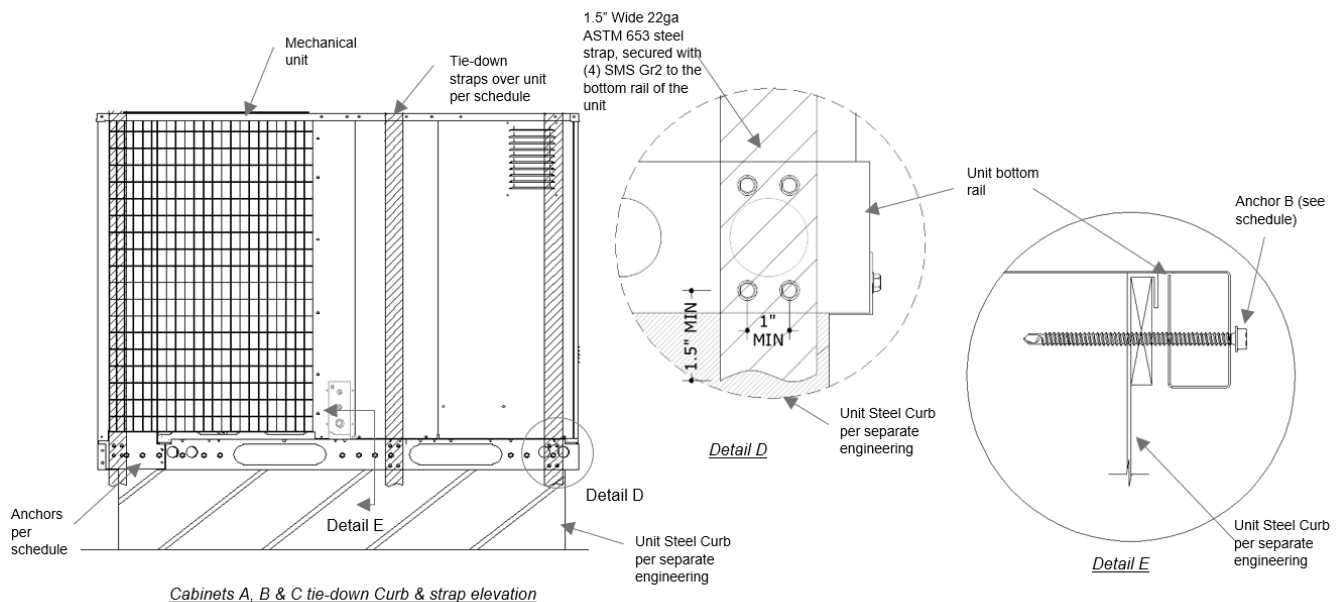
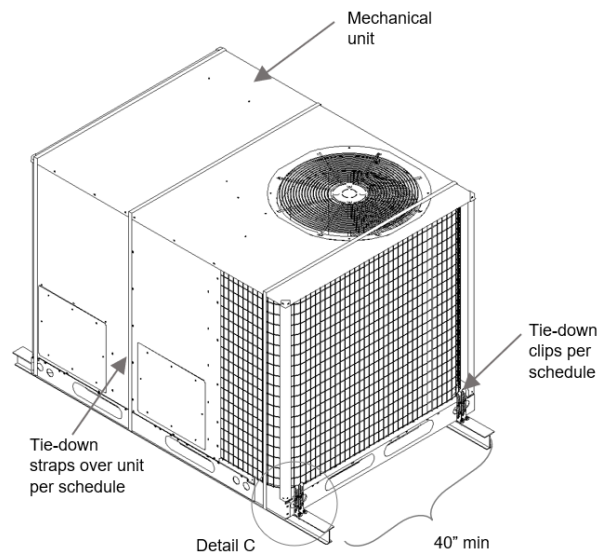
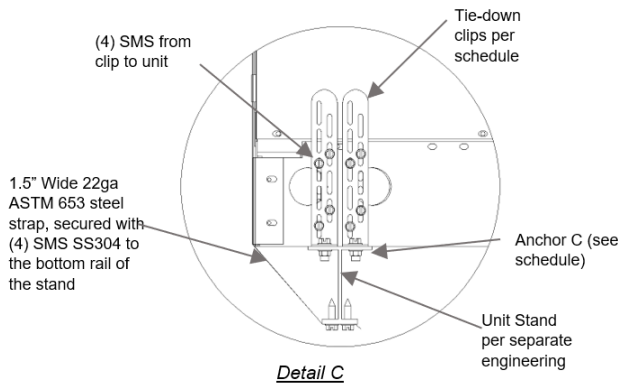

TIE-DOWN STRAP & CLIP SCHEDULE

Cabinet	Max. ASD Wind Pressures Lateral (Uplift)	Tie-down Strap	Strap Width & Thickness	Tie-down Clips to Ground	Tie-down Anchor to Curb	Tie-down Clip to Stand
A, B & C	± 54 psf (0 psf)	N/A	N/A	0S-4L	N/A	N/A
	± 118 psf (93 psf)	3	1.5" 22ga	N/A	10S-13L	8S-0L
D & E	± 54 psf (0 psf)	N/A	N/A	0S-4L	N/A	N/A
	± 118 psf (93 psf)	3	1.5" 22ga	N/A	N/A	8S-0L

- See Model Information tables herein for unit model cabinet classifications.
 - Tie-down Clip/ Anchor Designation: 1S= 1 clip per short side, 3L= 3 clips per long side.

Tie-down Strap & Clip Notes:

1. Minimum edge distance 3" from the unit corners.
2. Use # of tie-down straps per schedule.
3. Tie-down strap shall be wrapped and tightened to a snug fit around the unit and attached to the unit base rail, as shown in the detail page.
4. Neoprene pad shall be placed between the strap and the cabinet to prevent distortion or any damage (optional).
5. Tie-down clips shall be above layout or as shown in details.

ANCHOR TO HOST STRUCTURE SCHEDULE

Cabinet	Max. ASD Wind Pressures Lateral (Uplift)	Anchor Schedule to Host Structure By Others			
		3000 psi min. Concrete Host	16 GA. Min., A653 Gr. 33 min. Steel Curb	1/8" min. thick, ASTM A36 min. Steel Host	1/8" min. thick 6061-T6 Aluminum Host
A, B & C	± 54 psf (0 psf)	A	N/A	N/A	N/A
	± 118 psf (93 psf)	N/A	B	C	C
D & E	± 54 psf (0 psf)	A	N/A	N/A	N/A
	± 118 psf (93 psf)	N/A	N/A	C	C

Anchor Types to Host Structure:

- A.** – 1/4" ELCO ULTRACON Anchor embedded 1 3/4" in 3,000 psi concrete. 2 1/2" from edge minimum and 4" spacing.
B. – 3/8" Self-drilling screw Grade 5 screw minimum 5/8" from edges.
C. - 1/4" SS410 Thrubolt minimum 5/8" from edges, with 1.0" OD washer top & bottom and nut.
NA. - No anchors apply.

REMAINDER OF PAGE INTENTIONALLY LEFT BLANK

PANEL INTEGRITY SUMMARY

Cabinet	Install Condition	Panel Name	Rqrd Wind Pressure (lb/ft²)	Force on Panel (lbs)	Add'l Screw Qty Required (pcs)	Add'l screws required for original cabinet	Cabinet	Force on Panel (lbs)	Add'l Screw Qty Required (pcs)	Add'l screws required for original cabinet
Cabinet A Cabinet B Cabinet C	Ground	TOP PANEL	41.19	864.13	0	Yes	Cabinet D Cabinet E	453.67	0	No
		PANEL A	50.17	330.79	0			453.76	0	
		PANEL B	50.17	359.44	0			266.18	0	
		PANEL C	50.17	268.99	0			139.71	0	
		PANEL D	50.17	412.76	0			309.53	0	
		PANEL E	50.17	258.75	1			169.94	0	
		PANEL F	50.17	161.28	0			-	-	
		PANEL G	50.17	79.84	0			-	-	
	Roof	TOP PANEL	93.38	1959.11	0	Yes	0.00	0	Yes	
		PANEL A	118.29	779.90	1		1069.84	0		
		PANEL B	118.29	847.46	2		627.57	1		
		PANEL C	118.29	634.19	1		329.38	0		
		PANEL D	118.29	973.15	1		729.78	1		
		PANEL E	118.29	610.06	2		385.28	0		
PANEL F		118.29	380.26	0	-		-			
PANEL G	118.29	188.25	0	-	-					

PANEL INTEGRITY SUMMARY NOTES:

1. Calculations performed according to the information provided by the client. Cabinets were assumed solid (0% porosity) for shear and tension calculation purposes.
2. Screw quantities were checked to reinforce unit panels as needed. They shall be spaced evenly throughout the panel bottom part, validating that the screw joins the panel with the supporting element. Screw sizes, quantities on panel, and panel characteristics are according to client's description.
3. Additional screw shall be at least #10 Gr 2.
4. Installer shall insulate dissimilar metals.

REMAINDER OF PAGE INTENTIONALLY LEFT BLANK

TERMINOLOGY, CONTINUED

The following abbreviations may appear in this report: “Addtl.” for “additional”, “AHJ” for “Authority Having Jurisdiction”, “alum” for “aluminum”, “ASCE” for “American Society of Civil Engineers”, “ASD” for “Allowable Stress Design”, “ASTM” for “American Society for Testing and Materials”, “EA.” for “each”, “E.D.” for edge distance”, “EDDS” for “extra deep drawing steel”, “e.g.” for “*exempli gratia*” or “for example”, “equiv.” for “equivalent”, “FBC” for “Florida Building Code”, “FEA” for “Finite Element Analysis”, “FLCA” for “Florida Certificate of Authorization”, “FS” for “Florida Statutes”, “Fu” for “ultimate tensile strength” or “ultimate tensile stress”, “Fy” for “yield strength” or “yield stress”, “GA” for “gauge”, “GR.” or “Gr.” for “grade”, “HVAC” for “heating, ventilation, and air conditioning”, “HVHZ” for “High-Velocity Hurricane Zone”, “i.e.” for “*id est*” or “in other words”, “in” for “inch”, “lb” for “pound (force)”, “max.” for “maximum”, “min.” for “minimum”, “mm” for “millimeter”, “NTS” for “not to scale”, “O.C.” for “on center”, “OD” for “outer diameter”, “PE” for “Professional Engineer”, “qty” for “quantity”, “SAE” for “Society of Automotive Engineering”, “SMS” for “sheet metal screws”, “SS” for “stainless steel”, “TER” for “Technical Evaluation Report”, “typ.” for “typical”, “U.N.O.” for “unless noted otherwise”, “UTS” for “ultimate tensile strength” or “ultimate tensile stress”, “WLL” for “working load limit”, “w/o” for “without”, “YS” for “yield strength” or “yield stress”, “#” for “number”, “&” for “and”, and “Ø” for “diameter”. For additional abbreviation/terminology clarifications, please contact this office.

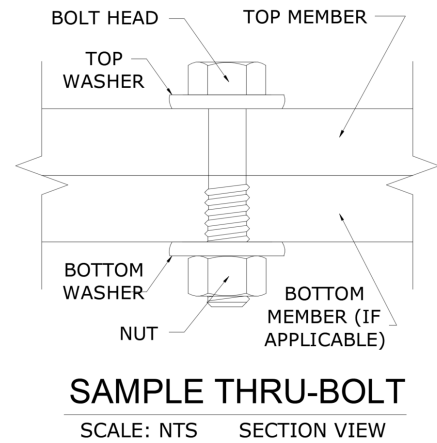

Note: The term “Thru-Bolt” or through bolt, if used herein, refers to a bolt passing through the member(s) in contact and is fastened by a nut at the end opposite the screw head. Nut shall be equivalent to or exceed the strength of the bolt U.N.O. Nut shall be sized to accommodate the same nominal diameter as the bolt U.N.O. See diagram above-right for a sample thru-bolt configuration.

Note: For instances herein which list material specifications as “[material type] or stronger”: U.N.O. herein, the term “stronger” refers to a material with a UTS value equal to or greater than the UTS value of the stated material type. Consult appropriate literature for established material UTS values.

Note: Equivalent steel gauge thicknesses as used in this evaluation, U.N.O., are as follows: 22 GA (.030”), 20 GA (.036”), 18 GA (.048”), 16 GA (.060”), 14 GA (.075”), 12 GA (.098”).

LIMITATIONS & CONDITIONS OF USE, CONTINUED

Use of this product shall be in strict accordance with this TER as noted herein. The supporting host structure shall be designed to resist all superimposed loads as determined by others on a site-specific basis as may be required by the authority having jurisdiction. Host structure conditions that are not accounted for in this product’s respective anchor schedule shall be designed for on a site-specific basis by a registered Professional Engineer. No evaluation is offered for the host supporting structure by use of this document. Adjustment factors noted herein and the applicable building codes must be considered, where applicable. Product components shall be of the material(s) specified in the manufacturer-provided product specifications. All supporting components which are permanently installed shall be protected against corrosion, contamination, and other such damage at all times. All fasteners and anchors shall be installed in accordance with the applicable provisions specified herein in addition to the anchor/fastener manufacturers’ published installation instructions. Fasteners must penetrate the supporting members such that the full length of the threaded portion is embedded within the main member.

All of the wind-resisting exterior panels (with accompanying retrofits) individually meet or exceed their capacity to resist the design wind loads as stated in the calculations as required by the codes and standards stated herein. Due to the indeterminate nature of these units, distortion, deflection, and material deformation cannot be accurately evaluated, but with the diaphragm action of external components and internal stiffeners, the base unit (with accompanying retrofits stated herein as applicable) has the capacity to withstand the design wind loads without detaching from the unit and becoming flying debris.

Survivability: Evaluation reports are valid for a newly installed unit and do not include certification of the product beyond a design event or if impacted by any debris. Inspections shall be implemented annually by the end user and after every named storm. All fasteners and cabinet components are to be verified, and all damaged, loose, corroded and/or broken fasteners and cabinet components shall be replaced to ensure structural integrity against hurricane wind forces. Contact this office for any reevaluation needs or as designated by the Authority Having Jurisdiction.

Durability: Components or component assemblies shall not deteriorate, crack, fail, or lose functionality due to galvanic corrosion or weathering. All supporting components which are permanently installed shall be protected against corrosion, contamination, and other such damage at all times. Each component or component assembly shall be supported and oriented in its intended installation position. All exposed plastic components shall be certified to resist sunlight exposure as specified by ASTM B117, or ASTM G155 in Broward or Miami Dade counties.

Extent of Certification: Certification pertains to the overall structural integrity of the unit components listed within the evaluation as required by code, subject to the limitations and criteria stated herein. Operability during or after a design event is not included in this certification. Water infiltration is outside the bounds of this certification. No other certifications are intended other than as described herein. This evaluation alone does not offer any evaluation for large missile impact debris or cyclic wind requirements unless specifically stated herein.

Proj. #	Remarks	By	Checked	Date	Proj. #	Remarks	By	Checked	Date
19-8163.2	Initial issue	EPR	LAO	02/10/20	22-55956	Add models, 2020 FBC update	MRT	EPR	10/04/2022
20-28489	TER Update	TT	RN	2020					

APPENDIX A: DESIGN WIND PRESSURE GUIDE

Max. Ult. Wind Speed (V _{ult})	Max. MRH (Roof Height)	Exposure Category	Required Design Wind Pressures (ASD)	
			Lateral Pressure	Uplift Pressure
140 mph	At-Grade (0 ft)	C	± 26 psf	0* psf
		D	± 31 psf	0* psf
	100 ft	C	± 63 psf	50 psf
		D	± 71 psf	56 psf
	200 ft	C	± 72 psf	57 psf
		D	± 80 psf	63 psf
175 mph	At-Grade (0 ft)	C	± 40 psf	0* psf
		D	± 49 psf	0* psf
	100 ft	C	± 98 psf	77 psf
		D	± 111 psf	87 psf
	200 ft	C	± 113 psf	89 psf
		D	± 124 psf	98 psf
186 mph	At-Grade (0 ft)	C	± 46 psf	0* psf
		D	± 54 psf	0* psf
	100 ft	C	± 111 psf	87 psf
		D	± 125 psf	99 psf
	200 ft	C	± 127 psf	100 psf
		D	± 140 psf	111 psf

~~100-psf~~ Note: Any table values with the format shown left, if present, indicate design wind pressures and site conditions that are **not approved for use** by this evaluation. Seek additional engineering or contact this firm for design solutions.

DIRECTIVE: This design pressure guide is for reference only and shall be approved for use by the Authority Having Jurisdiction (AHJ). If the design pressures listed in this guide are not used, required design pressures shall be calculated separately. For site-specific scenarios classified as Exposure Category B, the required design pressures stated for Exposure Category C in the above guide shall be used or design pressures shall be calculated separately. For heights and parameters beyond the parameters listed in this guide, visit our Online Calculator via the website link (<https://ecalc.io/forces>) or QR Code below, or obtain calculations separately by others.

The required ASD design pressures listed in this guide were calculated per the table's listed corresponding site conditions. The project design professional or permitting contractor shall verify that the site-specific conditions are equal to or less than the approved design parameters listed in the guide. Per the note below table: any values shown as "~~XX-psf~~", indicate wind pressures and corresponding site conditions that are **not valid for use** with this evaluation (exceeds the max. rated pressures).

*Note: Per the codes and standards referenced herein, uplift is not required for mechanical equipment at-grade. If uplift at-grade is required by the AHJ, contact this firm for a site-specific evaluation.

At-Grade (0 ft MRH) Required Design Pressures:

- o ASCE 7 "Design Wind Loads: Other Structures"
- o Structure Shape = Square, flat terrain
- o Height of structure (unit + stand or curb, if used) = 6 ft max.
- o Width of unit = 1 ft min., Depth of unit = 11 in min.

Rooftop (>15 ft MRH) Required Design Pressures:

- o ASCE 7 "Design Wind Loads: Other Structures: Rooftop Structures and Equipment for Buildings"
- o Structure Shape = Square, flat terrain
- o z = up to 7 ft, where z = height of stand or curb + ½ unit height
- o Lateral GC_r = 1.90; Uplift GC_r = 1.50

VISIT [ECALC.IO/FORCES](https://ecalc.io/forces)

FOR DESIGN AID CALCULATORS AND RESOURCES RELATED TO THIS TER & GUIDES HEREIN, OR SCAN THE QR CODE RIGHT >



UNIT REACTIONS FROM WIND GUIDE

DIRECTIVE: This guide is intended for use by a design professional. Design parameters shall abide all specifications and limitations stated in this report. Design professional shall consider all forces, including seismic and snow loads, per the governing building code. Unit reactions obtained from this guide shall be verified by a registered Professional Engineer. Reactions are applicable for unit-to-host connections only. Sample calculations are provided below.

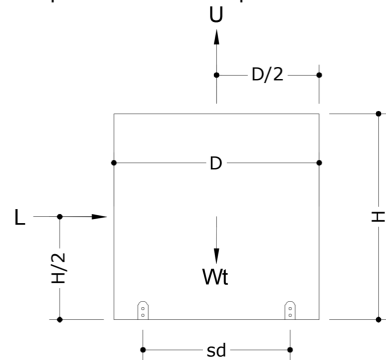

Design Parameters:

- Lateral Wind Pressure, P_{lat}
- Uplift Wind Pressure, P_{up}
- Unit Height, H
- Unit Depth, D
- Unit Width, W
- Unit Weight, Wt
- Support Spacing across Depth, sd
- Support Spacing across Width, sw

Unit Reaction Equations:

- Long Side (Width x Height):**
- Sliding Force, L = P_{lat} x W x H
 - Uplift Force, U = P_{up} x W x D
 - Total Tension per Long Side = (L x H/2 + U x sd/2 - Wt x 0.6 x sd/2) / sd
- Short Side (Depth x Height):**
- Sliding Force, L = P_{lat} x D x H
 - Uplift Force, U = P_{up} x W x D
 - Total Tension per Short Side = (L x H/2 + U x sw/2 - Wt x 0.6 x sw/2) / sw

Example: A (48" W x 36" D x 42" H), 250 lb net weight unit at wind pressures of 120 psf lateral and 95 psf uplift, on a 24" wide roof stand, shall have the following unit reactions:

Long Side (Width x Height):

1. Sliding Force, L = P_{lat} x W x H = (120 psf) x (48 in) x (42 in) x (1 in² / 144 ft²) = **1680 lb**
2. Uplift Force, U = P_{up} x W x D = (95 psf) x (48 in) x (36 in) x (1 in² / 144 ft²) = **1140 lb**
3. Total Tension per Long Side = (L x H/2 + U x sd/2 - Wt x 0.6 x sd/2) / sd = ((1680 lb x 42/2 in) + (1140 lb x 24/2 in) - (250 lb x 0.6 x 24/2 in)) / 24 in = **1965 lb**

Short Side (Depth x Height):

1. Sliding Force, L = P_{lat} x D x H = (120 psf) x (36 in) x (42 in) x (1 in² / 144 ft²) = **1260 lb**
2. Uplift Force, U = P_{up} x W x D = (95 psf) x (48 in) x (36 in) x (1 in² / 144 ft²) = **1140 lb**
3. Total Tension per Short Side = (L x H/2 + U x sw/2 - Wt x 0.6 x sw/2) / sw = ((1260 lb x 42/2 in) + (1140 lb x 48/2 in) - (250 lb x 0.6 x 48/2 in)) / 48 in = **1046 lb**

IN ALL CONDITIONS IT IS THE RESPONSIBILITY OF THE PERMIT HOLDER TO ENSURE THE HOST STRUCTURE IS CAPABLE OF WITHSTANDING THE RATED GRAVITY, LATERAL, AND UPLIFT FORCES BY SITE-SPECIFIC DESIGN. NO WARRANTY OF ANY KIND, EXPRESSED OR IMPLIED, IS OFFERED BY ENGINEERING EXPRESS AS TO THE INTEGRITY OF THE HOST STRUCTURE TO CARRY DESIGN FORCE LOADS INCURRED BY THIS UNIT.